

## RNA Series

## 18 – 40GHz Low Noise Amplifier

### Features

- Frequency Range: 18-40GHz
- Gain: 33dB
- P<sub>1dB</sub>: +13dBm
- OIP3: +27dBm
- Noise Figure: 3.5dB (typ.)
- DC Power: +8V @ 200mA
- RF Connector: 2.92mm-female

### Photo



### Description

RNA-1840-351333 is a wide band high performance Low Noise (& Driver) Amplifier, with standard frequency range of 18 to 40GHz.

### Electrical Specifications @+25 °C, Z<sub>in</sub>=Z<sub>out</sub>=50 Ω, DC Supply = +8VDC

Parameter	Unit	Minimum	Typical	Maximum
Frequency Range	GHz	18		32
Gain S <sub>21</sub>	f = 18GHz	28	31	
	f = 29GHz	30	33	
	f = 40GHz	31	34	
Gain Flatness	dB		±2.0	±3.0
Output Power P <sub>1dB</sub>	f = 29GHz	+10	+13	
Output Third Order Intercept IP3	f = 29GHz	+24	+27	
Noise Figure	f = 29GHz		3.5	4.5
Reverse Isolation S <sub>12</sub>	f = 29GHz	-55	-65	
Input VSWR S <sub>11</sub>	f = 29GHz		1.5:1	2.5:1
Output VSWR S <sub>22</sub>	f = 29GHz		1.5:1	2.5:1
DC Power Supply - voltage	V	+5.5	+8	+10
DC Power Supply - current	mA		200	250
Size (RF/DC feedthrough excluded)	Inch (mm)	1.772"x1.339"x0.335" (45x34x8.5mm)		
Weight	Oz	2.0		

**WARNING: MUST USE HEAT SINK OR MOUNT ON LARGE METAL PLATE**

## RNA Series

## 18 – 40GHz Low Noise Amplifier

### Gain S21, Isolation S12, Return Loss S11, S22 vs Frequency

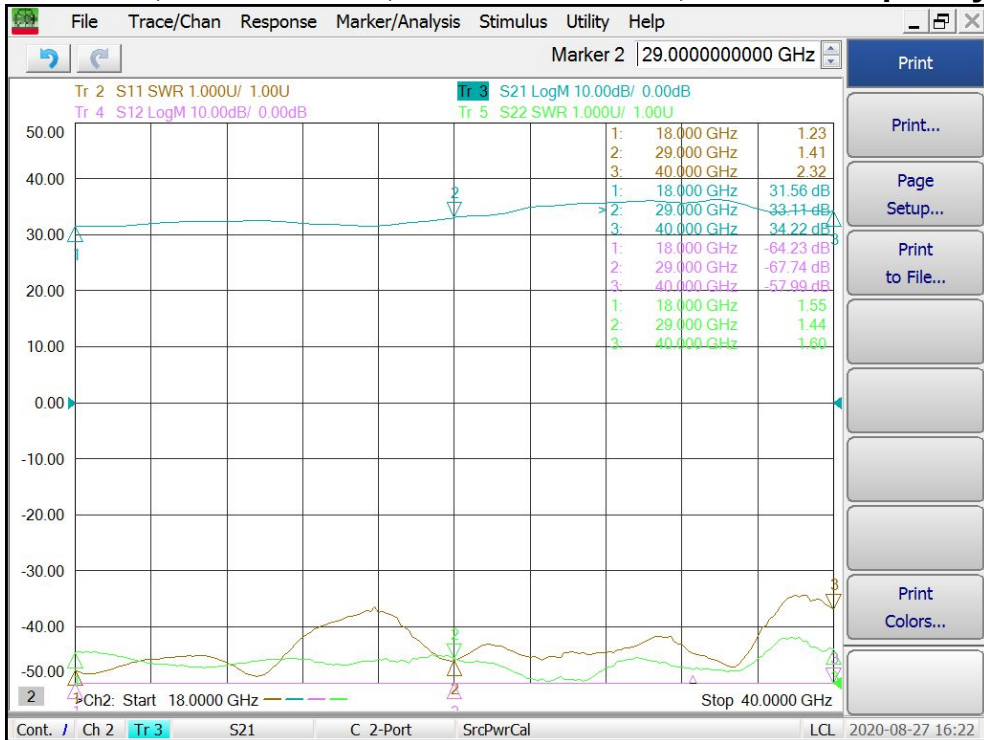

### Noise Figure vs Frequency

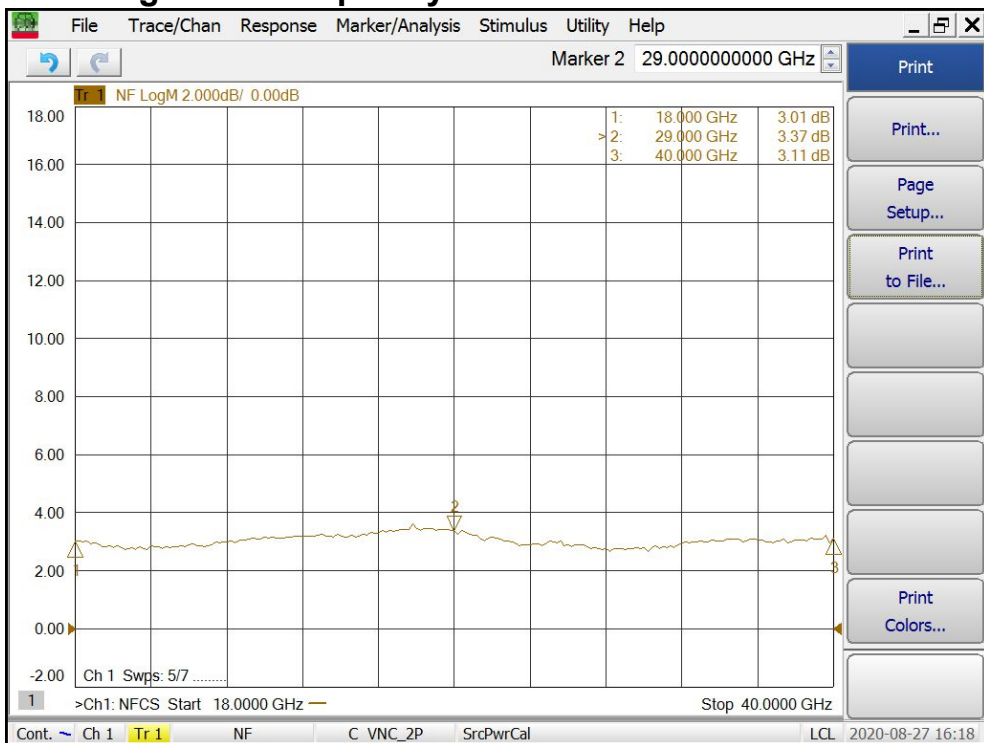

**Output P1dB vs Frequency**

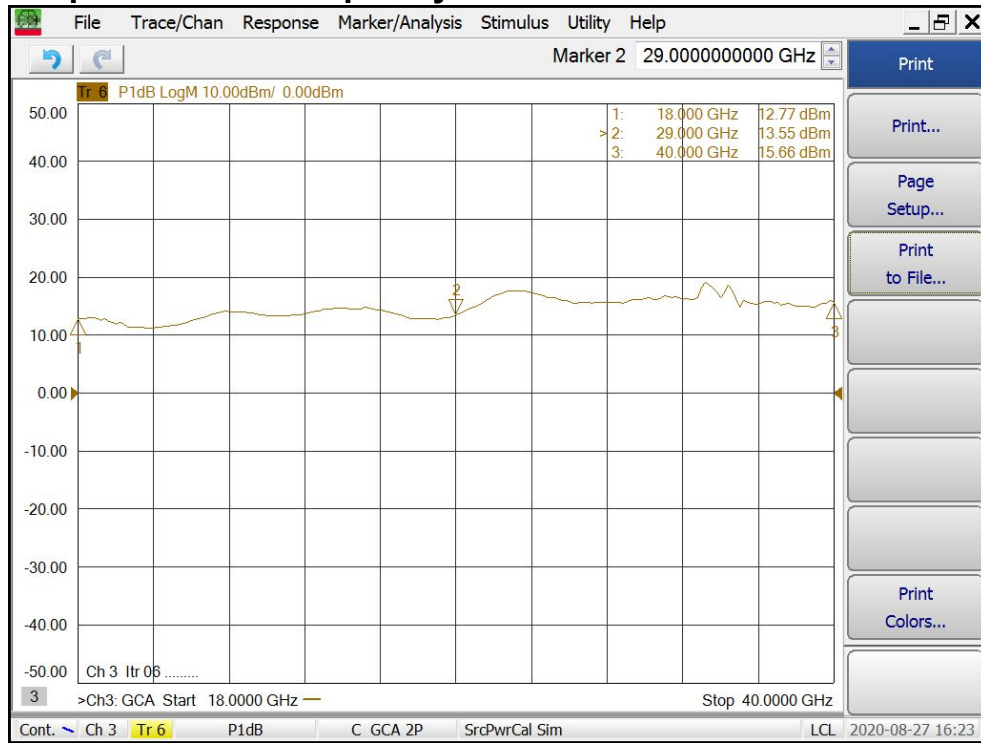

**Output IP3 vs Frequency**

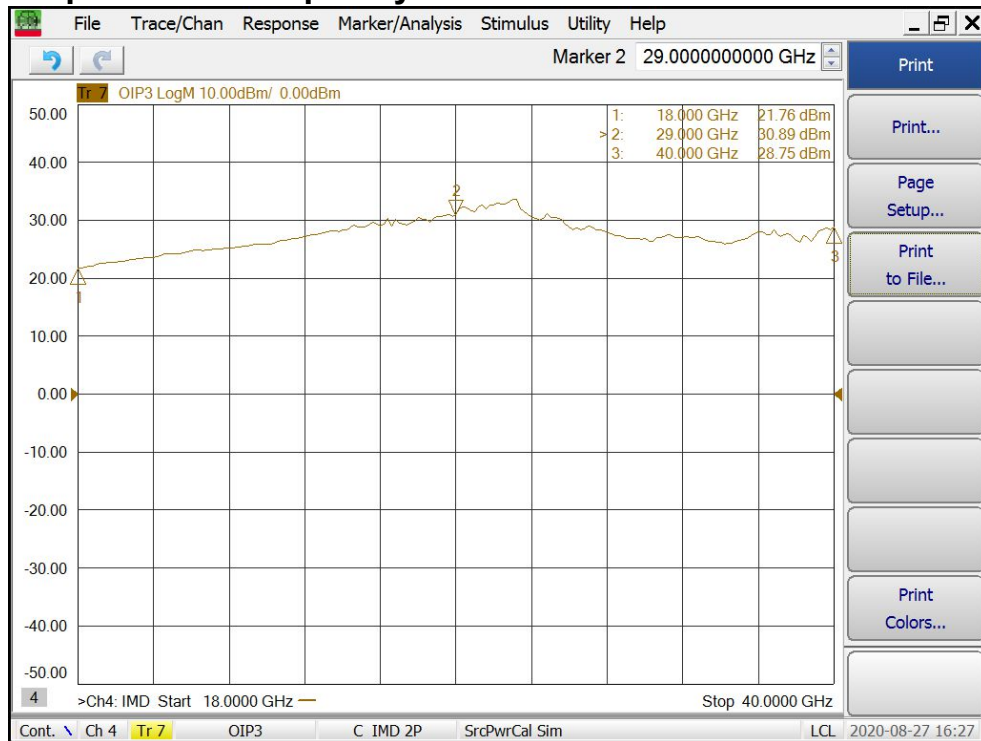

## RNA Series

## 18 – 40GHz Low Noise Amplifier

### Absolute Maximum Ratings

Parameter	Absolute Maximum
Supply Voltage	+10V
RF Input Power	+0dBm
Operating Temperature	-45 °C to +85 °C
Storage Temperature	-65 °C to +150 °C

### ESD Sensitive Material



### Outline

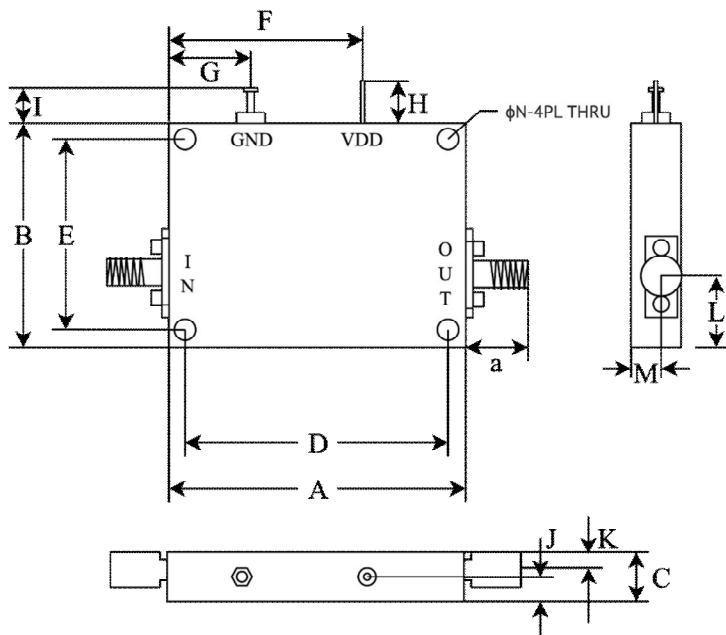

	A	B	C	D	E	F	G	H	I	J
Inch	1.772	1.339	0.335	1.614	1.181	1.075	0.256	0.256	0.197	0.167
mm	45.00	34.00	8.50	41.00	30.00	27.30	6.50	6.50	5.00	4.25

	K	L	M	N	a (SMA)	a (2.92mm)	a (2.4mm)	a (1.85mm)
Inch	0.130	0.390	0.205	0.087	0.370	0.374	0.425	0.445
mm	3.30	9.90	5.20	2.20	9.40	9.50	10.80	11.30